



Arion Solis 800w Series 19" Network Cabinet

Designed for the small business environment and low density server installations, it is a cost effective solution providing most features found in premium racks, without compromising on quality. A load capacity of 800 kg is more than enough to support the mixed equipment installations common to most IT rooms.

Our user friendly design will accept standard 19" equipment to organize your IT equipment.

Specifications

- The round holes perforated front and rear doors to increase the ventilation of the IT equipments inside up to 80% of the aperture.
- Half-height quick release side panels (left and right) with the key locks for safety and easy access to equipments for installation or maintenance.
- Be able to bear the weight of equipments up to 800 kgs.
- Cable pass through from top and bottom.
- Connected electrical grounding system.
- Depth adjustable PMA 20 mm increments with easy to read depth marking and "U" numbers printed on.
- Front and rear doors can be quickly installed or moved by the hinges with hinge lift-off design.
- Knock down design and flat pack for assemble readiness, more efficient and more convenient in shipping, stocking and assembly on the spot.

Design and Materials

- Made of premium grade GA Steel and Cold Roll Steel with the process of pre-treatment Iron Phosphate, De-Ionized Water Rinse and tested to 500 hours salt spray under ASTM-B117 (American Standard for Testing and Materials).
- Powder coating with the Electrostatic Powder Coat System producing the steady thickness and smoothness of the texture and industrial cure oven process to cohere the powder to its surface according to international standard ASTM D3363, ASTM D3359 and ASTM D522 for resistance against the scratches.
- Dimensions conform to EIA-310E, IEC-60297-1, 2.
- All materials RoHS compliant. 
- Designed and Manufactured under quality management standard of ISO 9001:2015 and environmental management standard of ISO 14001:2015.

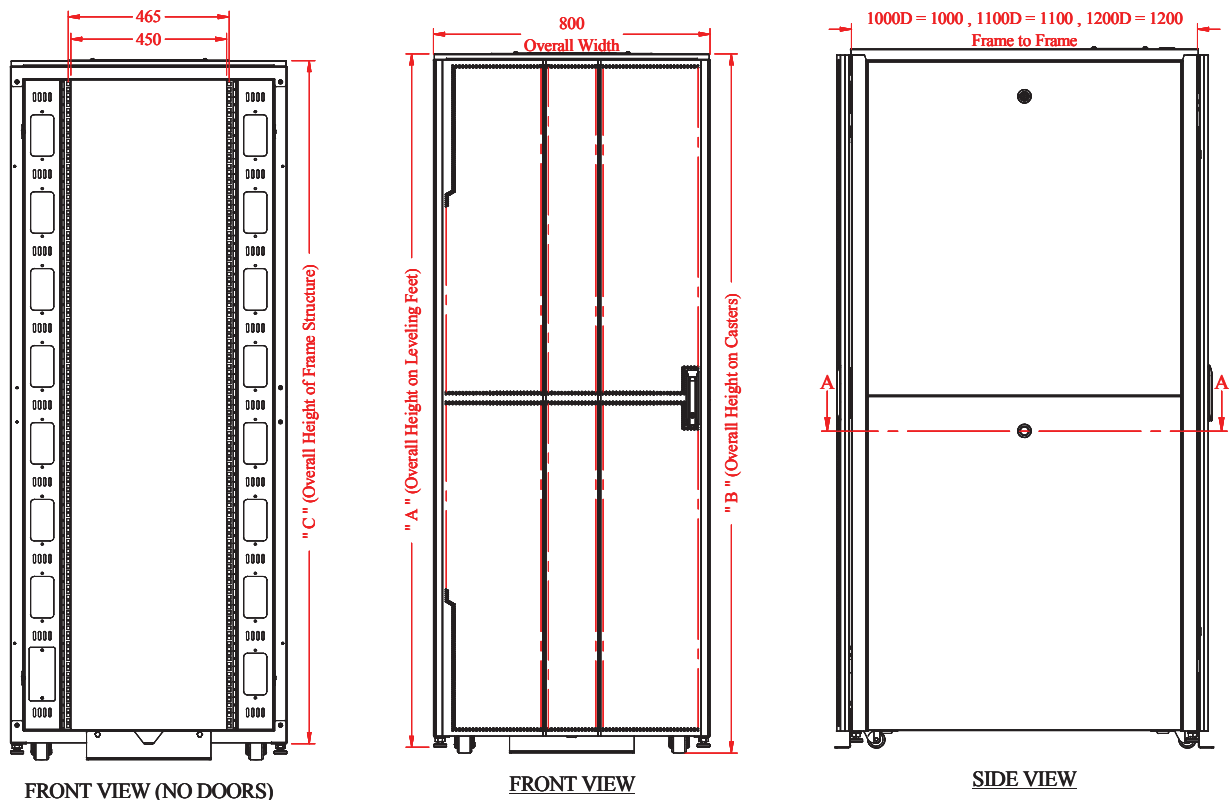

Dimensions (Unit : mm)			
Unit Height	Dim. "A"	Dim. "B"	Dim. "C"
42U	2003	2020	1973
45U	2136	2153	2106

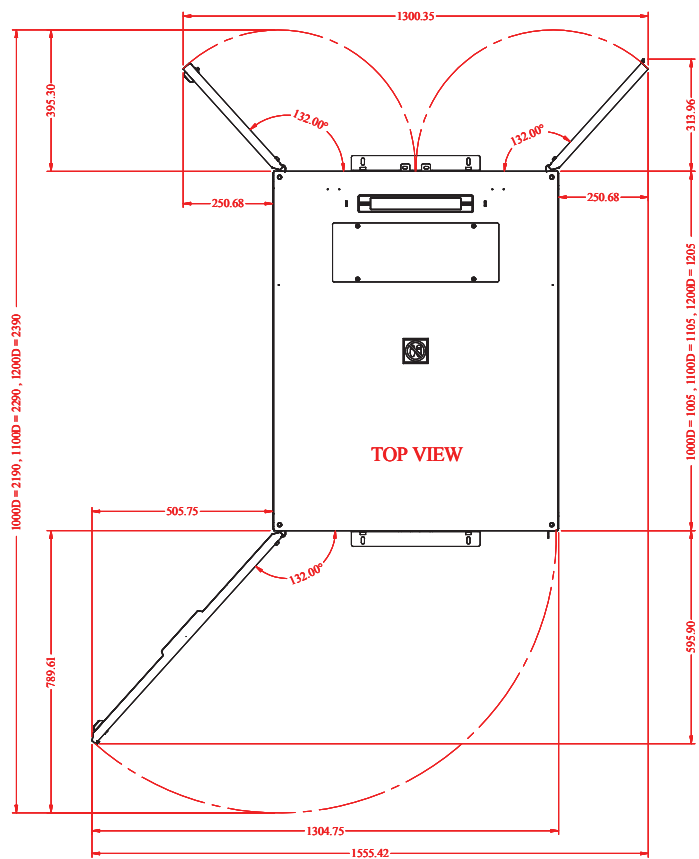
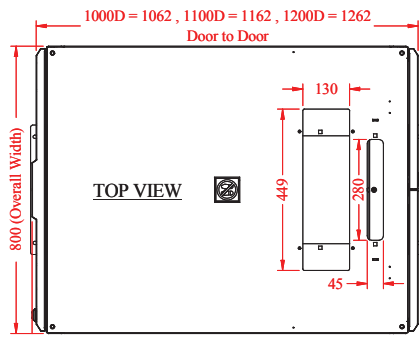

Description	1000D		1100D		1200D	
	42U	45U	42U	45U	42U	45U
Overall Height of Rack (include Casters)	2020	2153	2020	2153	2020	2153
Overall Depth, Door to Door	1065	1065	1165	1165	1265	1265
Rack Depth, Frame to Frame	1000	1000	1100	1100	1200	1200
Usable Rack Height	42U	45U	42U	45U	42U	45U
Net Weight (kg.) (include Casters)	109	114	113	118	118	123
Maximum Mounting Depth (mm.)	929	929	1029	1029	1129	1129
Single Door Total Open Area (sq. in.), all exceed 80%	1466	1571	1466	1571	1466	1571
Double Door Total Open Area (sq. in.), all exceed 80%	1397	1488	1397	1488	1397	1488
Door Opening Radius	132°	132°	132°	132°	132°	132°

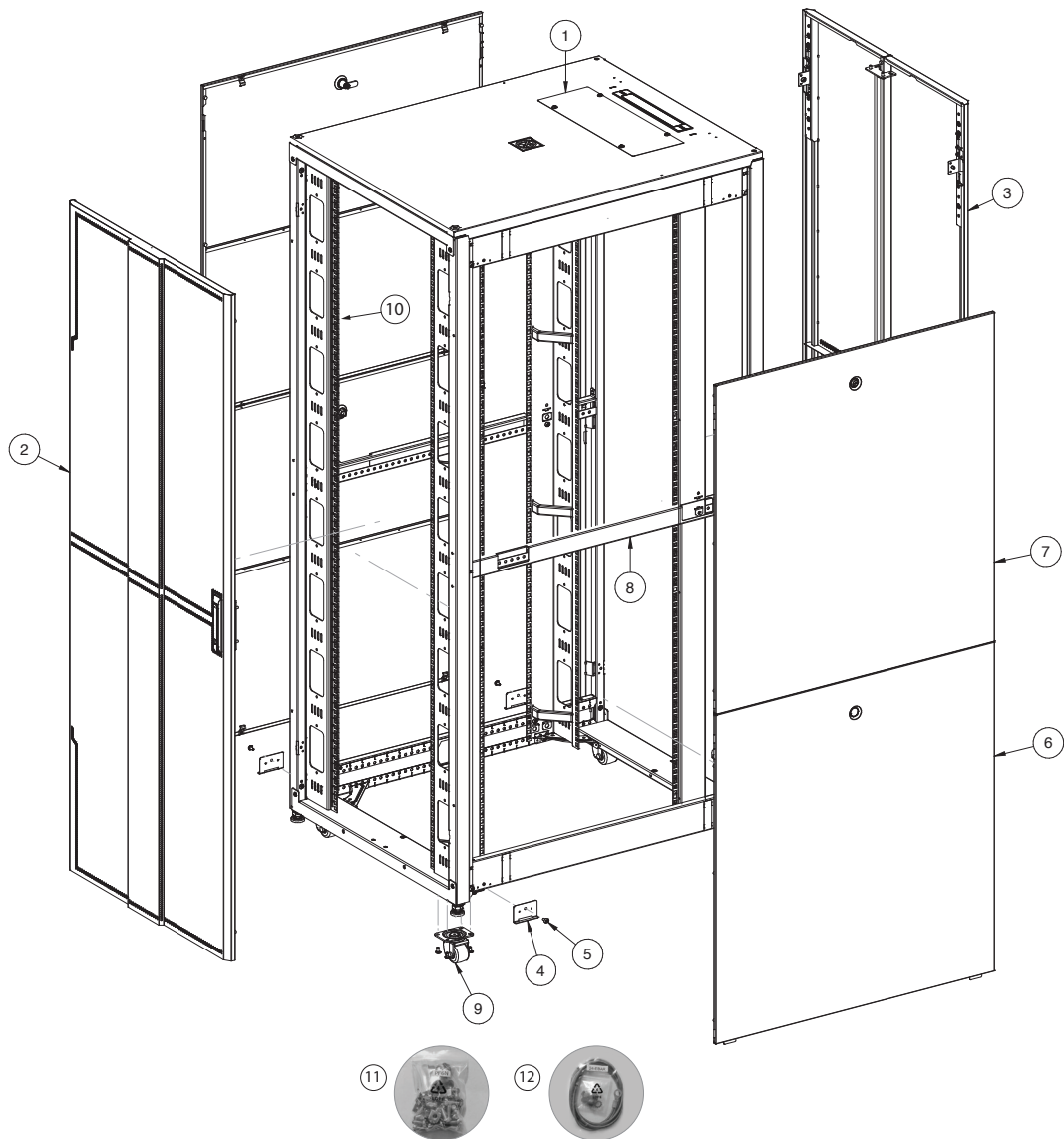

Item	Description	Qty.
1	Arion Solis Rack Basic 800Wx1000D-1200D,42U-45U	1
2	Door Perforate Assy. 800W/42U-45U	1
3	Door Split Perforate Kit. 800W/42U-45U	1
4	Side Panel Support Brkt.	4
5	Screw M6x12 Pan T30 BLK.	4
6	Side Panel Assy. (Bottom) 1000D-1200D/42U-45U	2
7	Side Panel Assy. (Top) 1000D-1200D/42U-45U	2
8	Side Brace (Middle) Welded 1000D-1200D	2
9	Caster 2 Inches (Cheval)	4
10	Side Channel Cover (Cutout 2.75 In) 800W/42U-45U	4
11	PF-6N Front Panel Fixing Kits (Pack of 20)	1
12	Earth Bond Kits AR	1